

# Bernie's Builds

[www.berniebuilds.com](http://www.berniebuilds.com)

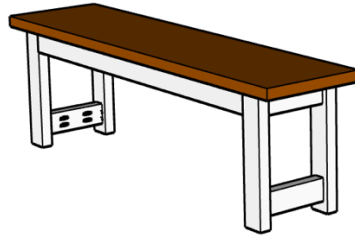

## MODERN FARMHOUSE BENCH

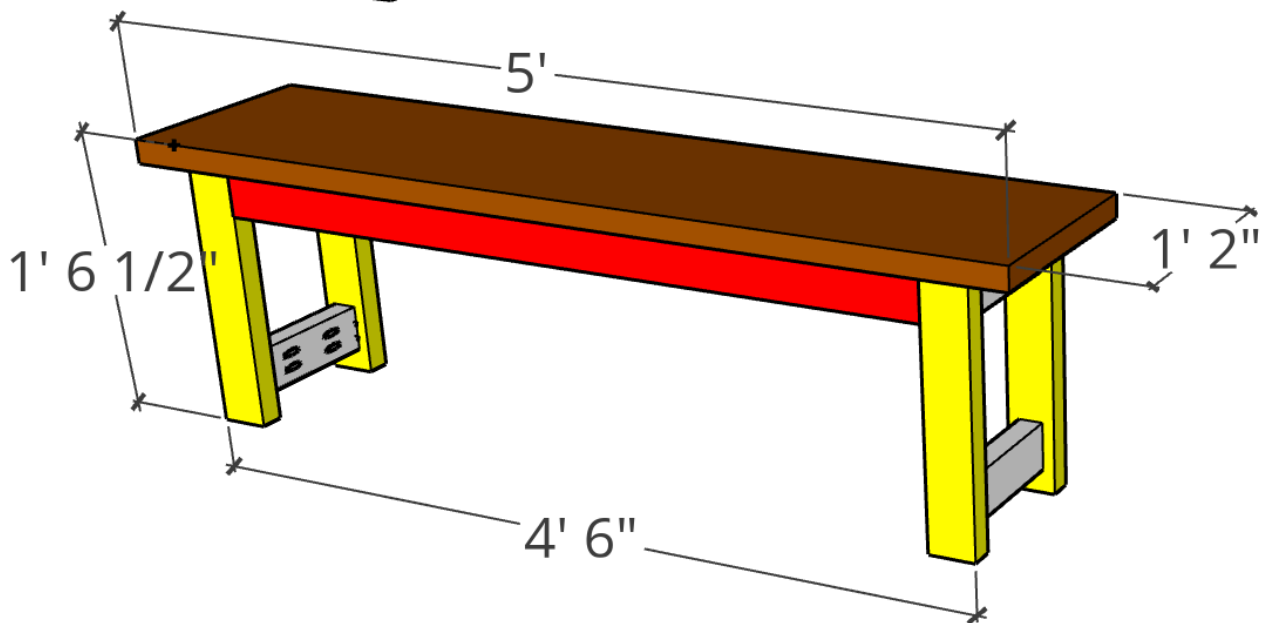

| Item                      | QTY |
|---------------------------|-----|
| 2x4x10                    | 2   |
| 2x8x10                    | 1   |
| 2 1/2" Pocket Hole Screws |     |
| Wood Glue                 |     |

# Cut List

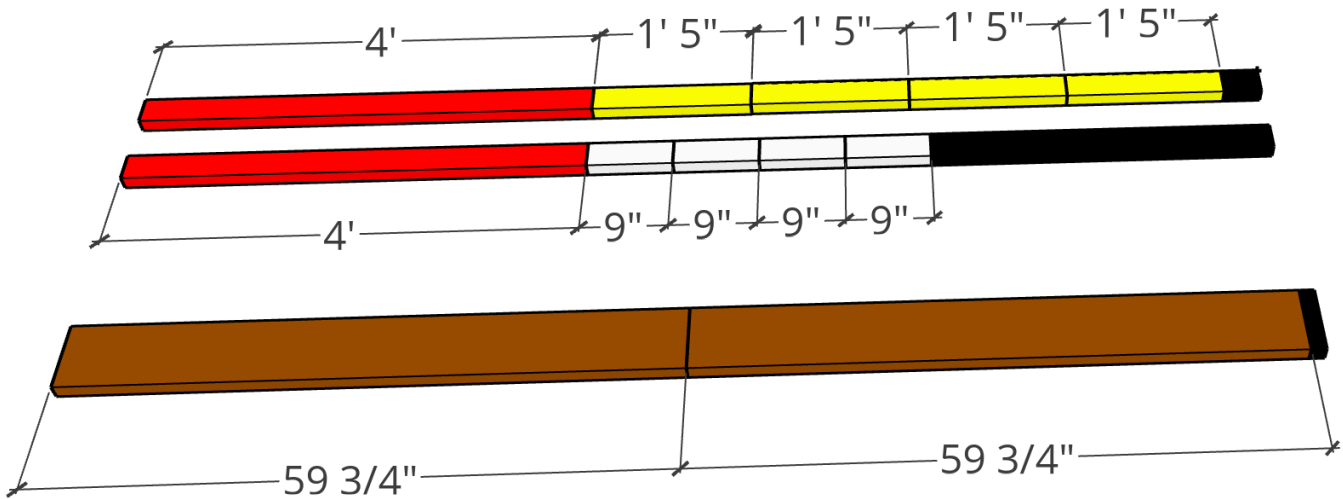

## NOTE

The 2x4 boards have been ripped from 3.5 inches to 3 inches. This is not necessary but make sure to adjust measurements to account for the difference in width of the boards. The 2x8 board has also been ripped to 7 inches to allow a smooth top.

# STEP 1

Make the cuts for the two-piece top. Then drill 1 ½ inch pocket holes. Apply glue for added strength, clamp the two boards together and attach with 2 ½ inch pocket hole screws.

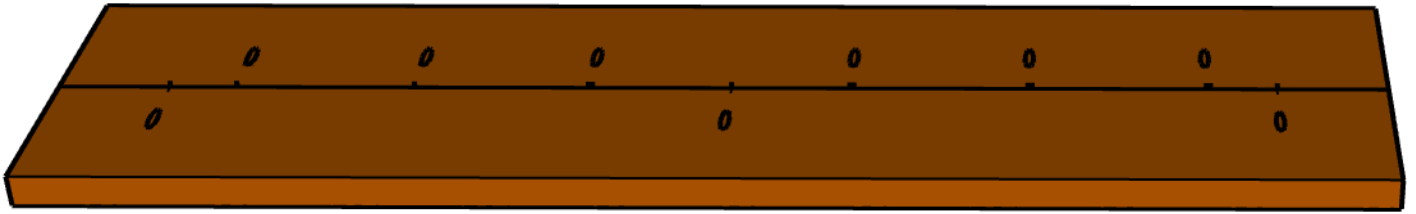

# Step 2

Cut the legs and short aprons to size. Drill 1 ½ inch pocket holes on the aprons. Attach the aprons to the legs with 2 ½ inch pocket hole screws and wood glue. The top apron should be flush with the top of the legs. The bottom apron should be 1 ½ inches from the bottom.

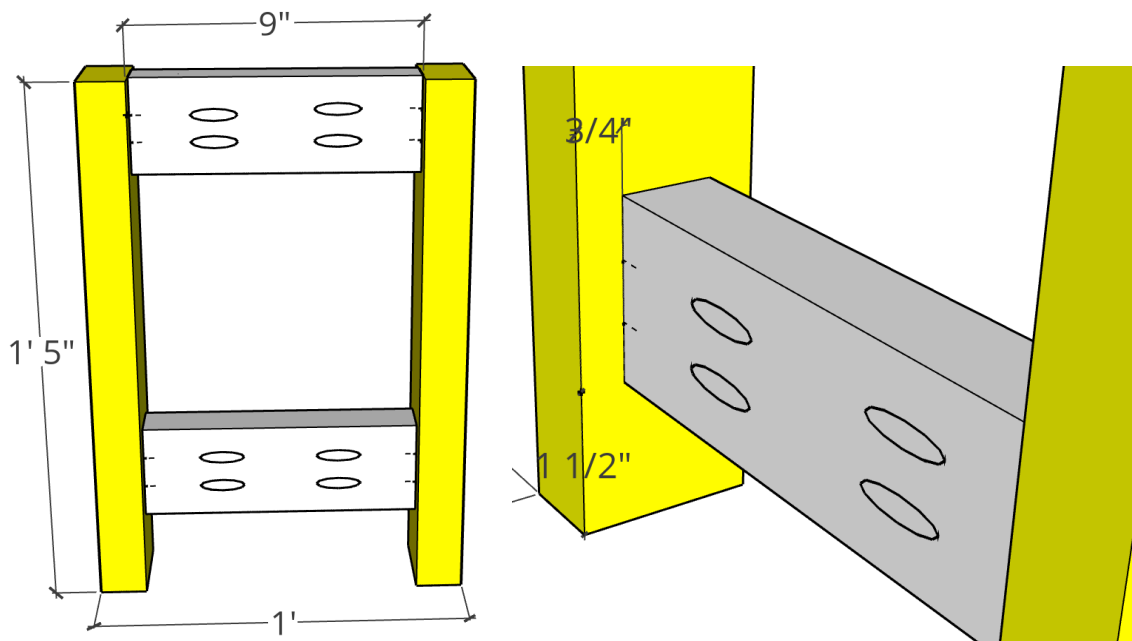

## Step 3

Cut the two longer aprons. Drill 1 ½ inch pocket holes on the aprons and attach to the sides with 2 ½ inch pocket hole screws and wood glue. Make sure the pocket holes to connect the top are facing in the correct direction.

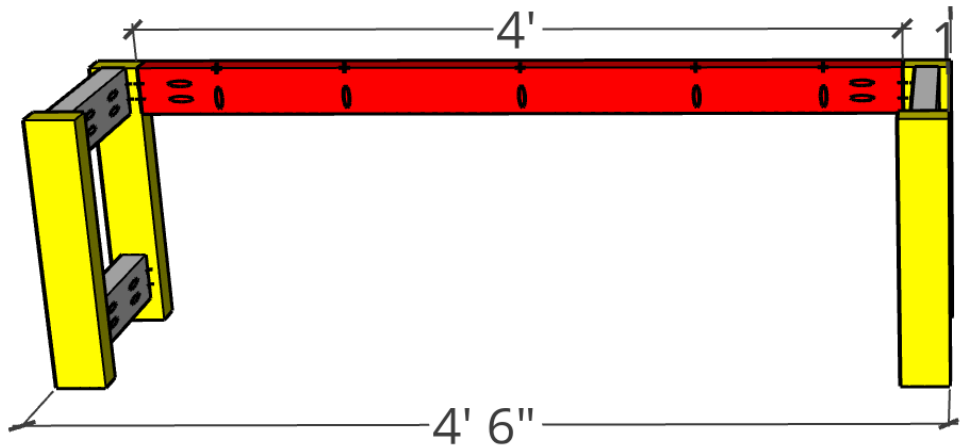

## Step 4

Lay the frame of the bench on top of the bottom of the top. Center it, add wood glue and 2 ½ inch pocket hole screws through the longer aprons.

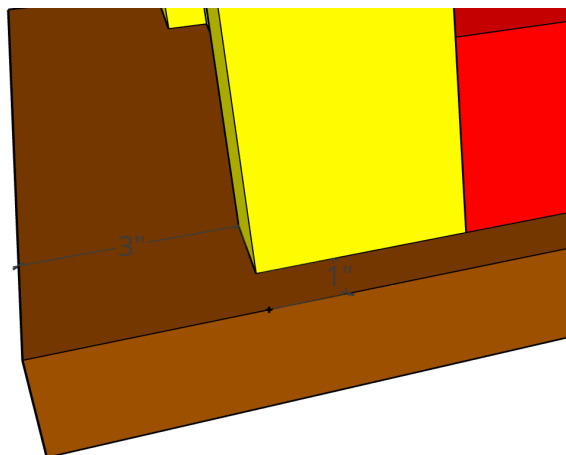

## Step 5

FINISH! Sand and then apply a paint or stain to get the look you like.  
Share your build and use #berniesbuilds!